



## Documentation

### R&R motor controller ST103 RR-P-468

Autor  
Stand  
Revision  
Steckerbelegung

Stefan Krämer  
Peter Seewang  
07.2007  
12.9.2007  
6.2.2008

**R&R motor control unit ST103**

1. RR-P-468 description motor controller board.....	3
2. Pin assignment .....	6
2.1 RR-P-486 .....	6
2.1.1 J2 RR-P-486 37pin Sub.-D header male .....	6
2.1.2 J3 RR-P-486 clamp connector power In .....	9
2.1.3 J4 RR-P-486 clamp connector power out .....	9
2.1.4 RR-P-486 Poti assignment.....	9
2.1.5 J5 RR-P-468 Service connector.....	9
2.2 power supply .....	10
2.2.1 power supply technical specification .....	10
2.2.2 J1 power connector.....	10
3. Connecting the modules .....	11
4. Software and serial Interface .....	12
4.1 Parameter.....	12
4.2 Telegrams of manager to the control modules .....	12
4.3 Telegrams of the control modules to the manager .....	12
4.4 Delay of the telegrams.....	12
4.5 Telegrams from manager to the control-modules .....	13
4.6 Telegrams from the control modules to manager .....	15
4.7 Calculation of the CRC-sign.....	17

Anlage Zeichnung DNR 16949

## 1. RR-P-468 description motor controller board

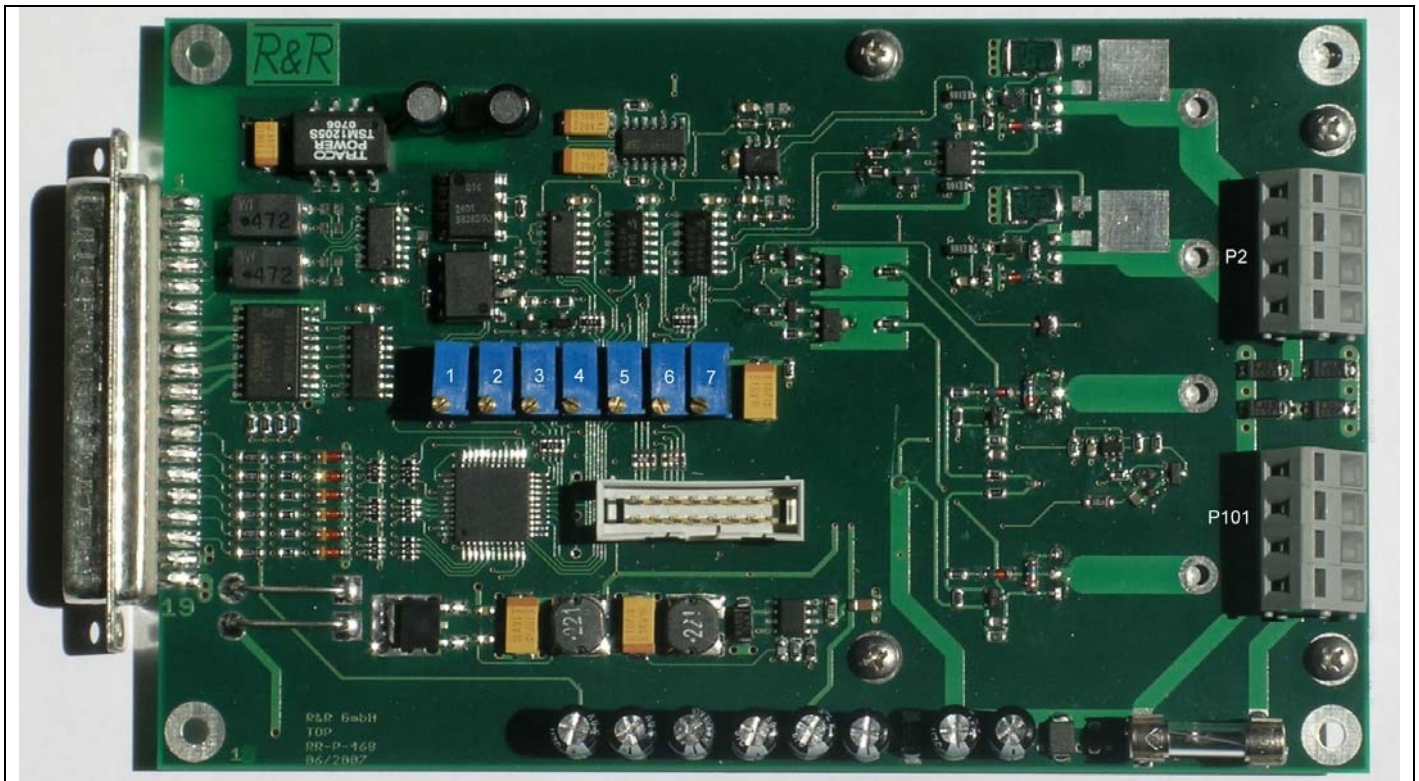

### Hardware

one full bridge for  
up to 36 volts supply voltage and  
up to 6 ampere load

following features works direct in hardware:  
overload sensors with delayed turn off  
inputs for end-switches und over temperature

following feature are done by microcontroller  
position control: start, stop, direction, speed control, serial communication

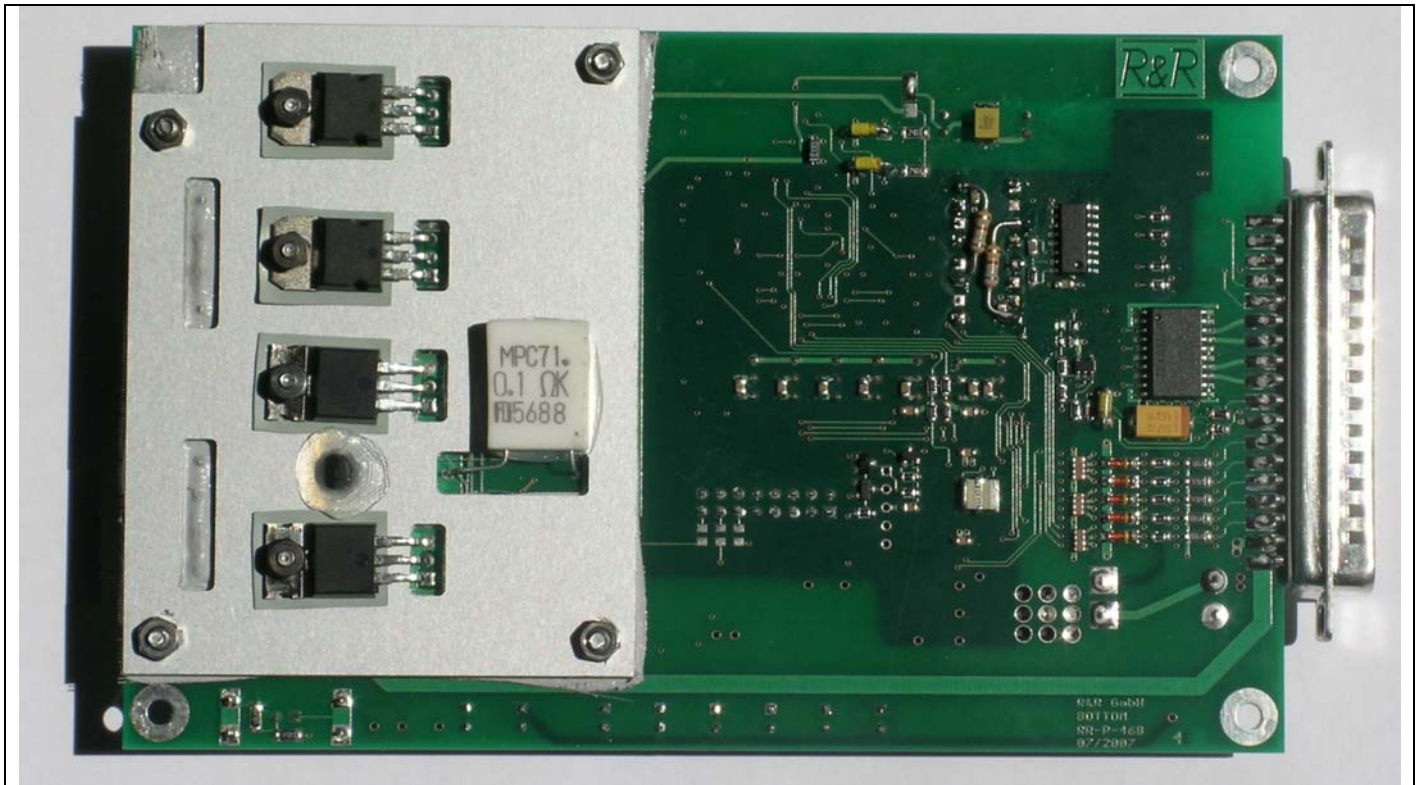

**digital inputs**

$V_{low}$	input < 8 volts	0
	$8V < \text{input} < 16 V$	undefined
$V_{high}$	input > 16 volts	1

All digital inputs have an internal pull up-resistor of 4.7 kΩ connected to +24V-DC  
 The reference point for the digital inputs is GND 0V ( Pin 18+36 of the connector )

**digital outputs**

high side switch, intern powered 24Volts  
 overload protected 4A, thermal shutdown

The return-path for the digital outputs is GND 0V ( Pin 18+36 of the connector )

**analogue input**

The analogue input is specified for an input voltage range from 0 volts to 5 volts  
 Connect the potentiometer to the pins 29, 11 and 30.

Potentiometer value 2.2 kΩ up to 22 kΩ

Attention!

Take care about the direction:

Moving in direction up = rising voltage

Accuracy  $\leq 1\%$  for operating temperature 0°C up to 40°C

**power output**

maximum continue current 5A ( low side switch ) adjustable thresholds and delay  
current limitation 7A ( short time ) ( high side switch )  
current limitation 6.3A by fuse

**security**

Motor current limiter and delay are done by hardware.



<b>housing</b>	aluminium anodized
W x D x H [mm <sup>3</sup> ]	128 x 200 x 65
drawing	DNR 16949

## 2. Pin assignment

### 2.1 RR-P-486

#### 2.1.1 J2 RR-P-486 37pin Sub.-D header male

J2 37pin Sub.-D header male		
Signal	PIN	Signal
-	1	
	20	-
-	2	
	21	-
-	3	
	22	-
RS422/485-A	4	
	23	RS422/485-B
RS422-Z	5	
	24	RS422-Y
(high side switch 24V) digital output 7	6	
	25	brake release (high side switch 24V)
(high side switch 24V) digital output 5	7	
	26	indicator 0% (high side switch 24V)
(high side switch 24V) indicator 25%	8	
	27	indicator 50% (high side switch 24V)
(high side switch 24V) indicator 75%	9	
	28	indicator 100% (high side switch 24V)
-	10	
	29	position sensor +5V
position sensor wiper	11	
	30	position sensor 0V
( digital input 7 )	12	
	31	goto 0%
goto 25%	13	
	32	goto 50%
goto 75%	14	
	33	goto 100%
run down	15	
	34	run up
bottom-stop	16	
	35	top-stop
over-temperature off	17	
	36	GND 0V ( digital inputs + outputs )
( digital inputs + outputs ) GND 0V	18	
	37	motor down+
motor up+	19	

signal	Type	description/function
brake release	digital – output / active high	output 24V up to 500mA connect the coil of the brake between this output and GND 0V
indicator 100%	digital – output / active high	output 24V for lamp or LED up to 100mA connect the Lamps/LEDs between these outputs and GND 0V
indicator 75%	digital – output / active high	
indicator 50%	digital – output / active high	
indicator 25%	digital – output / active high	
indicator 0%	digital – output / active high	
goto 100%	digital – input / switch NO	If this signal changes from high to low the motor is running to the position of top-end The motor will stop when: - a stop-input is high - or position-100% is reached
goto 75%	digital – input / switch NO	If this signal changes from high to low the motor is running to a position of 75% from bottom-end to top-end The motor will stop when: - a stop-input is high - or position-75% is reached
goto 50%	digital – input / switch NO	If this signal changes from high to low the motor is running to a position of 50 % from bottom-end to top-end The motor will stop when: - a stop input is high - or position-50% is reached
goto 25%	digital – input / switch NO	If this signal changes from high to low the motor is running to a position of 25 % from bottom-end to top-end The motor will stop when: - a stop input is high - or position-25% is reached
goto 0%	digital – input / switch NO	If this signal changes from high to low the motor is running to the position of bottom-end The motor will stop when: - a stop input is high - or position-0% is reached
run down	digital – input / switch NO	As long as this signal is low the motor is running down. The motor will stop also when: - bottom stop-input is high - or position bottom end is reached
run up	digital – input / switch NO	As long as this signal is low the motor is running up. The motor will stop also when: - top stop-input is high - or position top end is reached

al	type	description/function
bottom-stop	digital – input / switch NC	end-switch for bottom side, closed for normal operation
top-stop	digital – input / switch NC	end-switch for top-side, closed for normal operation the motor do not run up when this input is logical high
over-temperature off	digital – input / switch NC	If this input is logical high or open, the motor is turned off
position sensor wiper	analogue input	Input for position-sensor (potentiometer) The analogue input is specified for an input voltage range from 0 volts to 5 volts. Attention! Take care about the direction: Moving in direction up = rising voltage reference points for this signal are position sensor +5V and position sensor 0V connect the "position sensor"-pins only to the potentiometer
GND 0V	-	reference point for all digital inputs and all digital outputs
motor up+	power-output	this pin is positive when the motor is running up
motor down+	power-output	this pin is positive when the motor is running down



## 2.1.2 J3 RR-P-486 clamp connector power In

J3 Clamp connector P2 power IN		
1	GND	
2	GND	
3	IN +	
4	IN +	

## 2.1.3 J4 RR-P-486 clamp connector power out

J4 Clamp connector power output		
1	MOTOR DOWN+	
2	MOTOR DOWN+	
3	MOTOR UP+	
4	MOTOR UP+	

## 2.1.4 RR-P-486 Poti assignment

Poti assignment		
1	TOP-END	
2	BOTTOM-END	
3	SPEED-UP	
4	SPEED-DOWN	
5	CURRENT-UP	
6	CURRENT-DOWN	
7	DELAY	

## 2.1.5 J5 RR-P-468 Service connector

J5 Service-connector 16pin header male						
	Signal	PIN		Signal		
0..5V → 0..5A	current up	1	2	current down	0..5V → 0..5A	
0..5V → 0..0.5s	delay	3	4	bottom end	0..5V	
0..5V	top end	5	6	speed up	0..5V → duty cycle 0..100%	
0..5V → duty cycle 0..100%	speed down	7	8			
	0V	9	10	0V		
internal operating voltages decoupled with a 100 ohm resistor	+5V	11	12	-		
	+12V	13	14	-		
	+24V	15	16	-		

## 2.2 power supply

### 2.2.1 power supply technical specification

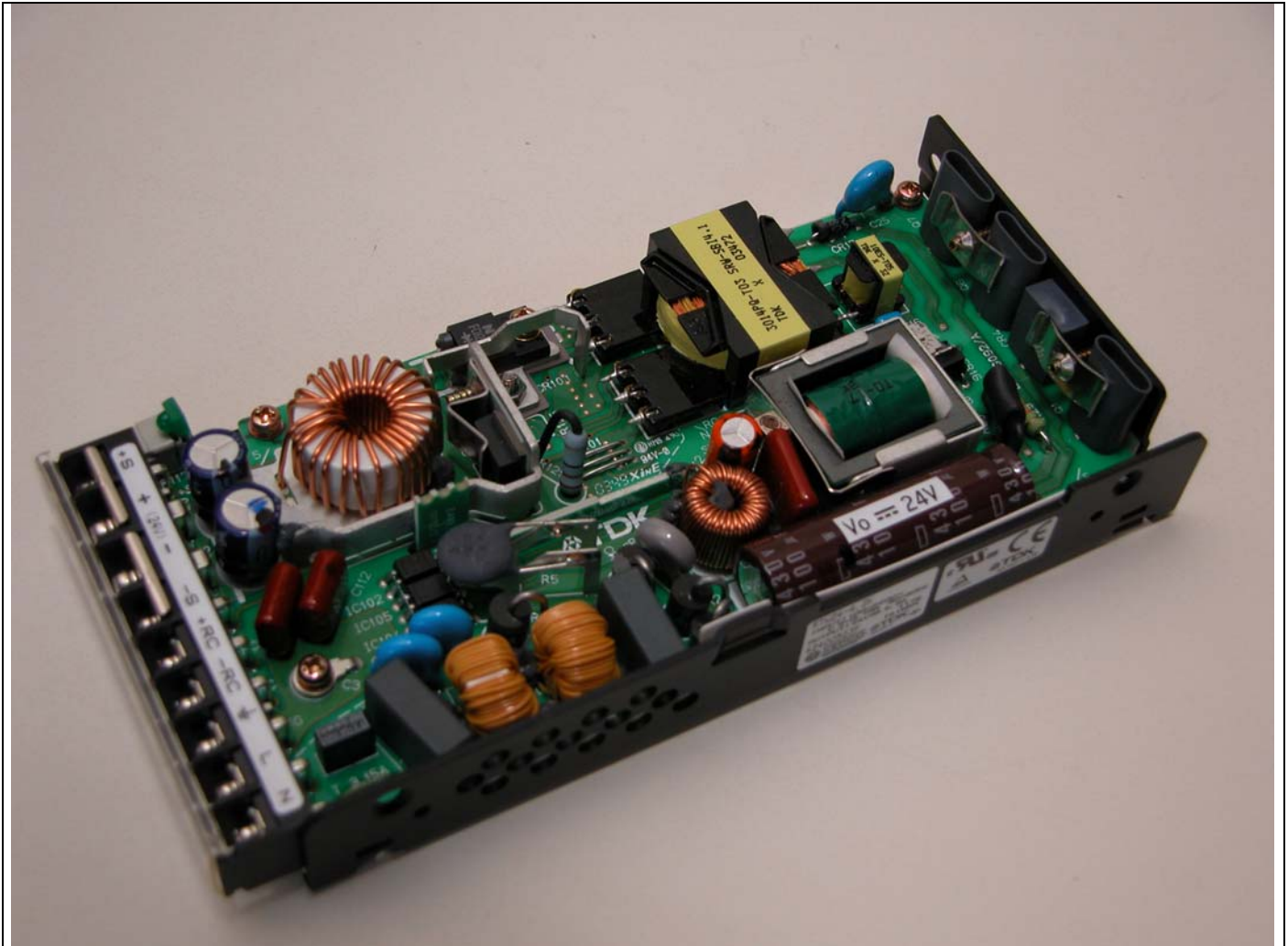

Power in	AC 100 – 120V , 220-240v a-c range 85-265V a-c / 110-370V d-c
Power out	24V DC, 3.6amps (100Watts)
Operating temp. nominal	-10 up to 71°C natural convection be aware of the derating (closed housing)

### 2.2.2 J1 power connector

J1 power connector		
A	L	
B	N	
C	PE	
Type	Serie 97 3polig Flanschstecker 97-3102A-10SL-3P	
Matching type	Serie 97 3polig Kupplung 97-3106A-10SL-3S	

### 3. Connecting the modules

All modules are with the manager, connected to a ring. I.e. the transmitter of the manager is connected with the receiver of the 1<sup>st</sup> control module. The transmitter of the 1<sup>st</sup> control module is connected with the receiver of the 2<sup>nd</sup> control module. The transmitter of the last control module is connected with the receiver of the manager. An automatic addressing assignment is achieved, in connection with the protocol by this wiring of the modules together. I.e. with no module an address must be put. The address of every module is determined by his position in the ring.

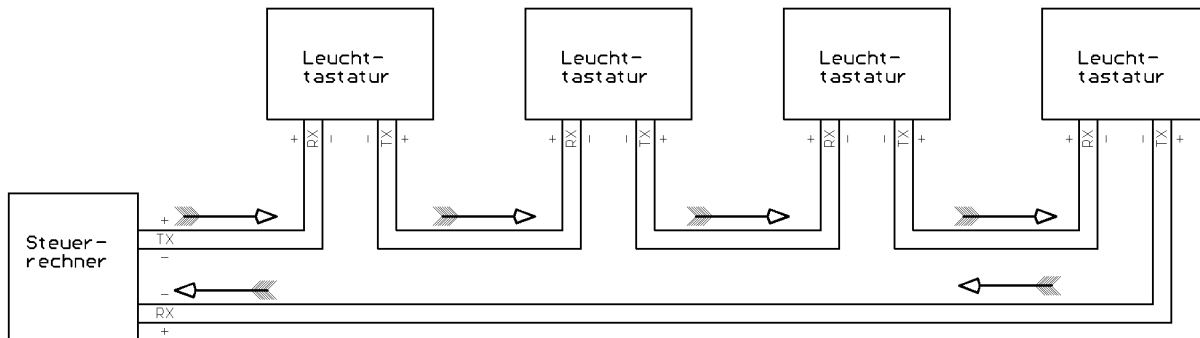

## 4. Software and serial Interface

### 4.1 Parameter

The parameters of the serial interface are:

Asynchrony serial 19200 baud, 8 data bits, no parity, 1 stop bit

Level = RS422

### 4.2 Telegrams of manager to the control modules

Every control module sends of every received byte immediately further. Besides, the module address (3<sup>rd</sup> byte) becomes decrement. The module which receives the module address 0 processes the telegram. The manager takes out the telegram of the ring.

### 4.3 Telegrams of the control modules to the manager

Telegrams are sent by every control module with the address 0. The following modules decrement the module addresses (3<sup>rd</sup> byte) just as with the command telegram. Besides, the control modules may interrupt no telegram. Only after the end of the last byte of a telegram the control module itself may send a telegram. During the transmitting of own telegram the control module must temporary store incoming bytes and send these bytes after ending of own telegram. Telegrams can be thereby delayed in the time of a telegram length (6 signs of 0.5 ms = 3 ms).

### 4.4 Delay of the telegrams

Because every control module sends a byte immediately after receipt, only one minimum delay originates per module.

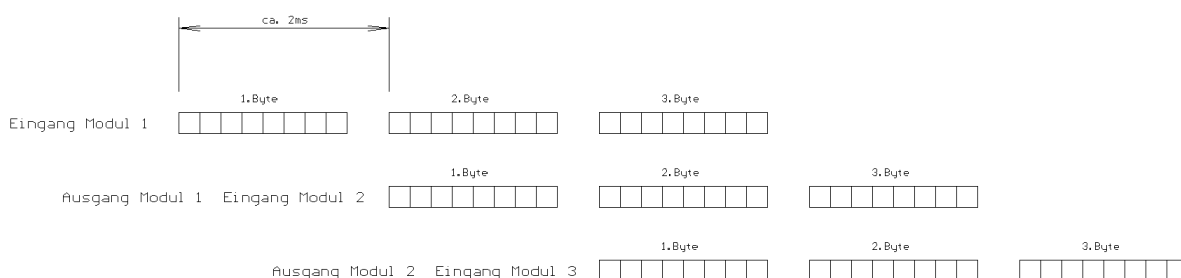

## 4.5 Telegrams from manager to the control-modules

Byte #	name	remark							
1	start-sign	STX+0x80 = 0x82							
2	command	0	1	D	C <sub>4</sub>	C <sub>3</sub>	C <sub>2</sub>	C <sub>1</sub>	C <sub>0</sub>
3	module-address <sup>*1</sup>	M <sub>7</sub>	M <sub>6</sub>	M <sub>5</sub>	M <sub>4</sub>	M <sub>3</sub>	M <sub>2</sub>	M <sub>1</sub>	M <sub>0</sub>
4	parameter	L <sub>7</sub>	L <sub>6</sub>	L <sub>5</sub>	L <sub>4</sub>	L <sub>3</sub>	L <sub>2</sub>	L <sub>1</sub>	L <sub>0</sub>
5	stop-sign	ETX+0x80 = 0x83							
6	check-character	CRC-sign 8bit							

D = direction: 0 means manager to controller-modules  
 M<sub>7</sub> to M<sub>0</sub> = module address -63 thru 0 thru 63<sup>\*1</sup>  
 C<sub>4</sub> to C<sub>0</sub> = command see following table  
 L<sub>7</sub> to L<sub>0</sub> = parameter  
<sup>\*1)</sup> becomes decremented while resending

commando-No.					command-name	remark / parameter																																																																																																																																																																		
C <sub>4</sub>	C <sub>3</sub>	C <sub>2</sub>	C <sub>1</sub>	C <sub>0</sub>																																																																																																																																																																				
0	0	0	0	0	RUN	0= STOP 1= UP 2= DOWN																																																																																																																																																																		
0	0	0	0	1	GOTO	position = 0..16 → 0..100% <table border="1" style="margin: 5px auto;"> <thead> <tr> <th>L<sub>7</sub></th> <th>L<sub>6</sub></th> <th>L<sub>5</sub></th> <th>L<sub>4</sub></th> <th>L<sub>3</sub></th> <th>L<sub>2</sub></th> <th>L<sub>1</sub></th> <th>L<sub>0</sub></th> <th></th> </tr> </thead> <tbody> <tr><td>0</td><td>0</td><td>0</td><td>0</td><td>0</td><td>0</td><td>0</td><td>0</td><td>0.00%</td></tr> <tr><td>0</td><td>0</td><td>0</td><td>0</td><td>0</td><td>0</td><td>0</td><td>1</td><td>6.25%</td></tr> <tr><td>0</td><td>0</td><td>0</td><td>0</td><td>0</td><td>0</td><td>1</td><td>0</td><td>12.50%</td></tr> <tr><td>0</td><td>0</td><td>0</td><td>0</td><td>0</td><td>0</td><td>1</td><td>1</td><td>18.75%</td></tr> <tr><td>0</td><td>0</td><td>0</td><td>0</td><td>0</td><td>1</td><td>0</td><td>0</td><td>25.00%</td></tr> <tr><td>0</td><td>0</td><td>0</td><td>0</td><td>0</td><td>1</td><td>0</td><td>1</td><td>31.25%</td></tr> <tr><td>0</td><td>0</td><td>0</td><td>0</td><td>0</td><td>1</td><td>1</td><td>0</td><td>37.50%</td></tr> <tr><td>0</td><td>0</td><td>0</td><td>0</td><td>0</td><td>1</td><td>1</td><td>1</td><td>43.75%</td></tr> <tr><td>0</td><td>0</td><td>0</td><td>0</td><td>1</td><td>0</td><td>0</td><td>0</td><td>50.00%</td></tr> <tr><td>0</td><td>0</td><td>0</td><td>0</td><td>1</td><td>0</td><td>0</td><td>1</td><td>56.25%</td></tr> <tr><td>0</td><td>0</td><td>0</td><td>0</td><td>1</td><td>0</td><td>1</td><td>0</td><td>62.50%</td></tr> <tr><td>0</td><td>0</td><td>0</td><td>0</td><td>1</td><td>0</td><td>1</td><td>1</td><td>68.75%</td></tr> <tr><td>0</td><td>0</td><td>0</td><td>0</td><td>1</td><td>1</td><td>0</td><td>0</td><td>75.00%</td></tr> <tr><td>0</td><td>0</td><td>0</td><td>0</td><td>1</td><td>1</td><td>0</td><td>1</td><td>81.25%</td></tr> <tr><td>0</td><td>0</td><td>0</td><td>0</td><td>1</td><td>1</td><td>1</td><td>0</td><td>87.50%</td></tr> <tr><td>0</td><td>0</td><td>0</td><td>0</td><td>1</td><td>1</td><td>1</td><td>1</td><td>93.75%</td></tr> <tr><td>0</td><td>0</td><td>0</td><td>1</td><td>0</td><td>0</td><td>0</td><td>0</td><td>100.00%</td></tr> </tbody> </table>	L <sub>7</sub>	L <sub>6</sub>	L <sub>5</sub>	L <sub>4</sub>	L <sub>3</sub>	L <sub>2</sub>	L <sub>1</sub>	L <sub>0</sub>		0	0	0	0	0	0	0	0	0.00%	0	0	0	0	0	0	0	1	6.25%	0	0	0	0	0	0	1	0	12.50%	0	0	0	0	0	0	1	1	18.75%	0	0	0	0	0	1	0	0	25.00%	0	0	0	0	0	1	0	1	31.25%	0	0	0	0	0	1	1	0	37.50%	0	0	0	0	0	1	1	1	43.75%	0	0	0	0	1	0	0	0	50.00%	0	0	0	0	1	0	0	1	56.25%	0	0	0	0	1	0	1	0	62.50%	0	0	0	0	1	0	1	1	68.75%	0	0	0	0	1	1	0	0	75.00%	0	0	0	0	1	1	0	1	81.25%	0	0	0	0	1	1	1	0	87.50%	0	0	0	0	1	1	1	1	93.75%	0	0	0	1	0	0	0	0	100.00%
L <sub>7</sub>	L <sub>6</sub>	L <sub>5</sub>	L <sub>4</sub>	L <sub>3</sub>	L <sub>2</sub>	L <sub>1</sub>	L <sub>0</sub>																																																																																																																																																																	
0	0	0	0	0	0	0	0	0.00%																																																																																																																																																																
0	0	0	0	0	0	0	1	6.25%																																																																																																																																																																
0	0	0	0	0	0	1	0	12.50%																																																																																																																																																																
0	0	0	0	0	0	1	1	18.75%																																																																																																																																																																
0	0	0	0	0	1	0	0	25.00%																																																																																																																																																																
0	0	0	0	0	1	0	1	31.25%																																																																																																																																																																
0	0	0	0	0	1	1	0	37.50%																																																																																																																																																																
0	0	0	0	0	1	1	1	43.75%																																																																																																																																																																
0	0	0	0	1	0	0	0	50.00%																																																																																																																																																																
0	0	0	0	1	0	0	1	56.25%																																																																																																																																																																
0	0	0	0	1	0	1	0	62.50%																																																																																																																																																																
0	0	0	0	1	0	1	1	68.75%																																																																																																																																																																
0	0	0	0	1	1	0	0	75.00%																																																																																																																																																																
0	0	0	0	1	1	0	1	81.25%																																																																																																																																																																
0	0	0	0	1	1	1	0	87.50%																																																																																																																																																																
0	0	0	0	1	1	1	1	93.75%																																																																																																																																																																
0	0	0	1	0	0	0	0	100.00%																																																																																																																																																																

command-No					command-name	remark / parameter																								
C <sub>4</sub>	C <sub>3</sub>	C <sub>2</sub>	C <sub>1</sub>	C <sub>0</sub>																										
0	0	0	1	0	set ramp	$0..15^{3/4}$ default value 8.00 = 01000000 = 001000.00 format <table border="1"> <thead> <tr> <th>L<sub>7</sub></th> <th>L<sub>6</sub></th> <th>L<sub>5</sub></th> <th>L<sub>4</sub></th> <th>L<sub>3</sub></th> <th>L<sub>2</sub></th> <th>L<sub>1</sub></th> <th>L<sub>0</sub></th> </tr> </thead> <tbody> <tr> <td>0</td> <td>0</td> <td>x</td> <td>x</td> <td>x</td> <td>x</td> <td>.y</td> <td>y</td> </tr> <tr> <td>0</td> <td>0</td> <td>1</td> <td>0</td> <td>0</td> <td>.0</td> <td>0</td> <td>0</td> </tr> </tbody> </table> xxxx = pre decimal signs yy = post decimal signs	L <sub>7</sub>	L <sub>6</sub>	L <sub>5</sub>	L <sub>4</sub>	L <sub>3</sub>	L <sub>2</sub>	L <sub>1</sub>	L <sub>0</sub>	0	0	x	x	x	x	.y	y	0	0	1	0	0	.0	0	0
L <sub>7</sub>	L <sub>6</sub>	L <sub>5</sub>	L <sub>4</sub>	L <sub>3</sub>	L <sub>2</sub>	L <sub>1</sub>	L <sub>0</sub>																							
0	0	x	x	x	x	.y	y																							
0	0	1	0	0	.0	0	0																							
0	0	0	1	1	set IR-compensation	$0..3^{15/16}$ default value 1.000 = 00010000 = 0001.0000 format <table border="1"> <thead> <tr> <th>L<sub>7</sub></th> <th>L<sub>6</sub></th> <th>L<sub>5</sub></th> <th>L<sub>4</sub></th> <th>L<sub>3</sub></th> <th>L<sub>2</sub></th> <th>L<sub>1</sub></th> <th>L<sub>0</sub></th> </tr> </thead> <tbody> <tr> <td>0</td> <td>0</td> <td>x</td> <td>x</td> <td>.y</td> <td>y</td> <td>y</td> <td>y</td> </tr> <tr> <td>0</td> <td>0</td> <td>0</td> <td>1</td> <td>.0</td> <td>0</td> <td>0</td> <td>0</td> </tr> </tbody> </table> xx = pre decimal signs yyyy = post decimal signs	L <sub>7</sub>	L <sub>6</sub>	L <sub>5</sub>	L <sub>4</sub>	L <sub>3</sub>	L <sub>2</sub>	L <sub>1</sub>	L <sub>0</sub>	0	0	x	x	.y	y	y	y	0	0	0	1	.0	0	0	0
L <sub>7</sub>	L <sub>6</sub>	L <sub>5</sub>	L <sub>4</sub>	L <sub>3</sub>	L <sub>2</sub>	L <sub>1</sub>	L <sub>0</sub>																							
0	0	x	x	.y	y	y	y																							
0	0	0	1	.0	0	0	0																							
0	0	1	0	0	save parameter	-																								
0	0	1	0	1	get position	topically measured value																								
0	0	1	1	0	get current up	topically measured value																								
0	0	1	1	1	get current down	topically measured value																								
0	1	0	0	0	get speed up	potentiometer value																								
0	1	0	0	1	get speed down	potentiometer value																								
0	1	0	1	0	get top end	potentiometer value																								
0	1	0	1	1	get bottom end	potentiometer value																								
0	1	1	0	0	get safety switches	therm_off, top_stop, bottom_stop																								
0	1	1	0	1																										
0	1	1	1	0	get ramp	actual value																								
0	1	1	1	1	get IR-compensation	actual value																								
1	?	?	?	?		command C <sub>3</sub> ..C <sub>0</sub> for all modules																								

## 4.6 Telegrams from the control modules to manager

Byte #	name	remark							
1	start-sign	STX+0x80 = 0x82							
2	command	0	1	D	C <sub>4</sub>	C <sub>3</sub>	C <sub>2</sub>	C <sub>1</sub>	C <sub>0</sub>
3	module-address <sup>*1</sup>	M <sub>7</sub>	M <sub>6</sub>	M <sub>5</sub>	M <sub>4</sub>	M <sub>3</sub>	M <sub>2</sub>	M <sub>1</sub>	M <sub>0</sub>
4	parameter	L <sub>7</sub>	L <sub>6</sub>	L <sub>5</sub>	L <sub>4</sub>	L <sub>3</sub>	L <sub>2</sub>	L <sub>1</sub>	L <sub>0</sub>
5	stop-sign	ETX+0x80 = 0x83							
6	check-character	CRC-sign 8bit							

D = direction: 1 mean controller modules to manager

M<sub>7</sub> to M<sub>0</sub> = module-address -63 thru 0 thru 63<sup>\*1</sup>

C<sub>4</sub> to C<sub>0</sub> = command see following table

L<sub>7</sub> to L<sub>0</sub> = parameter

\*1) becomes decremented while resending

\*1) the module send a message always with address = 0

command-#					message name	remark / parameter
C <sub>4</sub>	C <sub>3</sub>	C <sub>2</sub>	C <sub>1</sub>	C <sub>0</sub>		
0	0	0	0	0	RUN ended	0 = stop-command 1 = position reached 2 = over current 3 = user break 4 = break by end-switches
0	0	0	0	1	GOTO ended	0 = stop-command 1 = position reached 2 = over current 4 = break by end-switches
0	0	0	1	0	-	-
0	0	0	1	1	-	-
0	0	1	0	0	parameter saved	0 → error 1 → ok
0	0	1	0	1	get position	topically measured value 10 bits, 0..1023 send in format #2
0	0	1	1	0	get current up	topically measured value 10 bits, 0..1023 send in format #2
0	0	1	1	1	get current down	topically measured value 10 bits, 0..1023 send in format #2
0	1	0	0	0	get speed up	potentiometer value 10 bits, 0..1023 send in format #2
0	1	0	0	1	get speed down	potentiometer value 10 bits, 0..1023 send in format #2
0	1	0	1	0	get top end	potentiometer value 10 bits, 0..1023 send in format #2

0	1	0	1	1	get bottom end	potentiometer value 10 bits, 0..1023 send in format #2																								
0	1	1	0	0	get safety switches	<table border="1"> <tr> <td>L<sub>7</sub></td><td>L<sub>6</sub></td><td>L<sub>5</sub></td><td>L<sub>4</sub></td><td>L<sub>3</sub></td><td>L<sub>2</sub></td><td>L<sub>1</sub></td><td>L<sub>0</sub></td> </tr> <tr> <td>0</td><td>0</td><td>0</td><td>0</td><td>0</td><td>X</td><td>X</td><td>X</td> </tr> </table> <p>L<sub>0</sub> = bottom_stop L<sub>1</sub> = top_stop L<sub>2</sub> = therm off</p>	L <sub>7</sub>	L <sub>6</sub>	L <sub>5</sub>	L <sub>4</sub>	L <sub>3</sub>	L <sub>2</sub>	L <sub>1</sub>	L <sub>0</sub>	0	0	0	0	0	X	X	X								
L <sub>7</sub>	L <sub>6</sub>	L <sub>5</sub>	L <sub>4</sub>	L <sub>3</sub>	L <sub>2</sub>	L <sub>1</sub>	L <sub>0</sub>																							
0	0	0	0	0	X	X	X																							
0	1	1	0	1	-	-																								
0	1	1	1	0	get ramp	actual value 6 bits, 0..63, send in format #1																								
0	1	1	1	1	get IR-compensation	actual value 6 bits, 0..63, send in format #1																								
for	all	from			for all status-answer telegrams	format #1																								
0	0	1	0	1		<table border="1"> <tr> <td>L<sub>7</sub></td><td>L<sub>6</sub></td><td>L<sub>5</sub></td><td>L<sub>4</sub></td><td>L<sub>3</sub></td><td>L<sub>2</sub></td><td>L<sub>1</sub></td><td>L<sub>0</sub></td> </tr> <tr> <td>0</td><td>0</td><td>X</td><td>X</td><td>X</td><td>X</td><td>X</td><td>X</td> </tr> </table> <p>XXXXXX = up to 6 bit value</p>	L <sub>7</sub>	L <sub>6</sub>	L <sub>5</sub>	L <sub>4</sub>	L <sub>3</sub>	L <sub>2</sub>	L <sub>1</sub>	L <sub>0</sub>	0	0	X	X	X	X	X	X								
L <sub>7</sub>	L <sub>6</sub>	L <sub>5</sub>	L <sub>4</sub>	L <sub>3</sub>		L <sub>2</sub>	L <sub>1</sub>	L <sub>0</sub>																						
0	0	X	X	X	X	X	X																							
to					format #2																									
						<table border="1"> <tr> <td>L<sub>7</sub></td><td>L<sub>6</sub></td><td>L<sub>5</sub></td><td>L<sub>4</sub></td><td>L<sub>3</sub></td><td>L<sub>2</sub></td><td>L<sub>1</sub></td><td>L<sub>0</sub></td> </tr> <tr> <td>0</td><td>1</td><td>L</td><td>L</td><td>L</td><td>L</td><td>L</td><td>L</td> </tr> <tr> <td>1</td><td>1</td><td>H</td><td>H</td><td>H</td><td>H</td><td>H</td><td>H</td> </tr> </table> <p>HHHHHLLLLLLL = up to 12 bit value send in 2 telegrams</p>	L <sub>7</sub>	L <sub>6</sub>	L <sub>5</sub>	L <sub>4</sub>	L <sub>3</sub>	L <sub>2</sub>	L <sub>1</sub>	L <sub>0</sub>	0	1	L	L	L	L	L	L	1	1	H	H	H	H	H	H
L <sub>7</sub>	L <sub>6</sub>	L <sub>5</sub>	L <sub>4</sub>	L <sub>3</sub>	L <sub>2</sub>	L <sub>1</sub>	L <sub>0</sub>																							
0	1	L	L	L	L	L	L																							
1	1	H	H	H	H	H	H																							
0	1	1	1	1																										



#### 4.7 Calculation of the CRC-sign

The following program segment describes the calculation of the CRC-sign.

The type U8 is an unsigned 8 bit variable (0 to 255, 0x00 to 0xFF)

The function `put_tx_buffer( U8 c )` transmit a character via the serial interface.

```
#define POLYNOM 0xB1 // 28+27+25+24+20+1
#define INIT_TX_CRC {tx_crc=0xA5;}
```

```
U8 tx_crc ;
```

```
void build_tx_crc8( U8 a )
{
    U8 i=8 ;
    do
    {
        if (( a & 0x01 ) != ( tx_crc & 0x01 ))
        {
            tx_crc >>= 1 ;
            tx_crc ^= POLYNOM ;
        }
        else
        {
            tx_crc >>= 1 ;
        }
        a >>= 1 ;
    }
    while (--i!=0) ;
}
```

```
void send_command( U8 address, U8 command, U8 parameter )
{
    INIT_TX_CRC ;
    put_tx_buffer( STX+0x80 ) ; build_tx_crc8( STX+0x80 ) ;
    put_tx_buffer( command ) ; build_tx_crc8( command ) ;
    put_tx_buffer( address ) ; build_tx_crc8( address ) ;
    put_tx_buffer( parameter ) ; build_tx_crc8( parameter ) ;
    put_tx_buffer( ETX+0x80 ) ; build_tx_crc8( ETX+0x80 ) ;
    put_tx_buffer( tx_crc ) ;
}
```

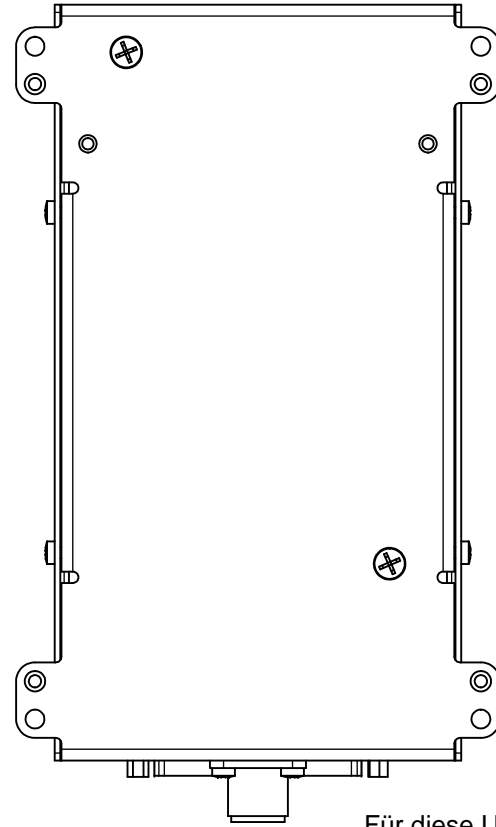
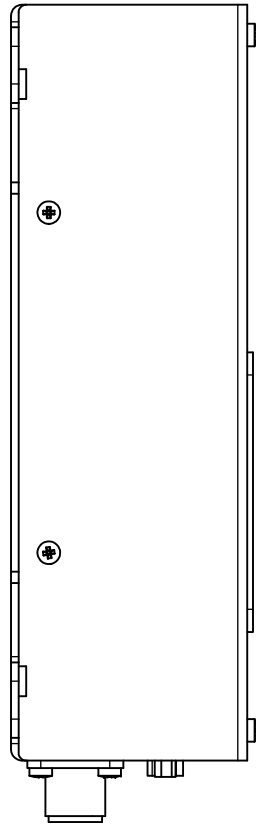
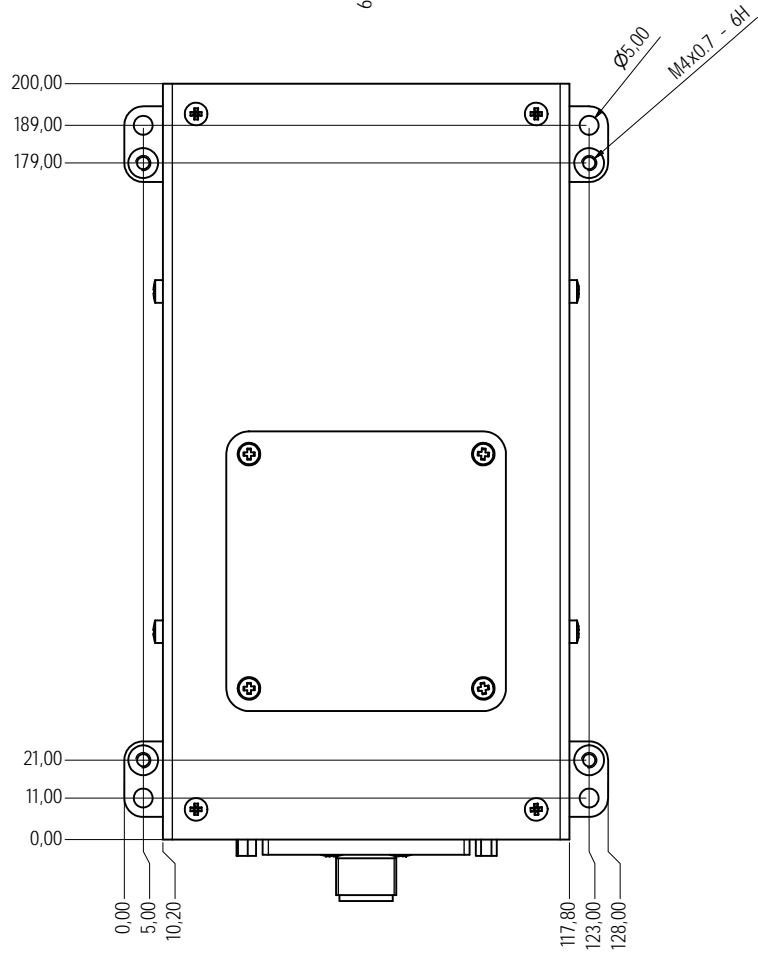
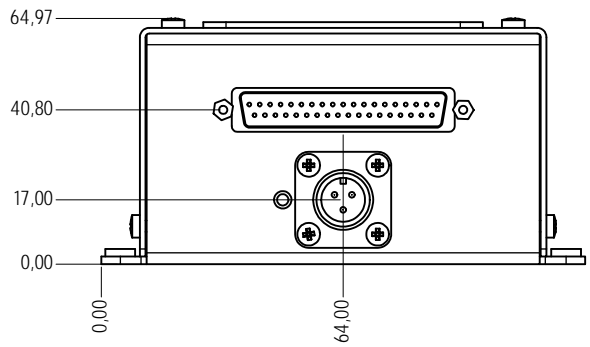

Für diese Unterlagen behalten wir uns alle Rechte vor (DIN 34)

Ges. f. Rationalisierung und Rechentechnik mbH Ob der Eck 4 78148 Gutenbach		Datum	Name	ST103 Baugruppe
		12.09.2007	ps	
		gezeichnet		
		kontrolliert		
				dnr16949
				1
				A2
Status	Änderungen	Datum	Name	

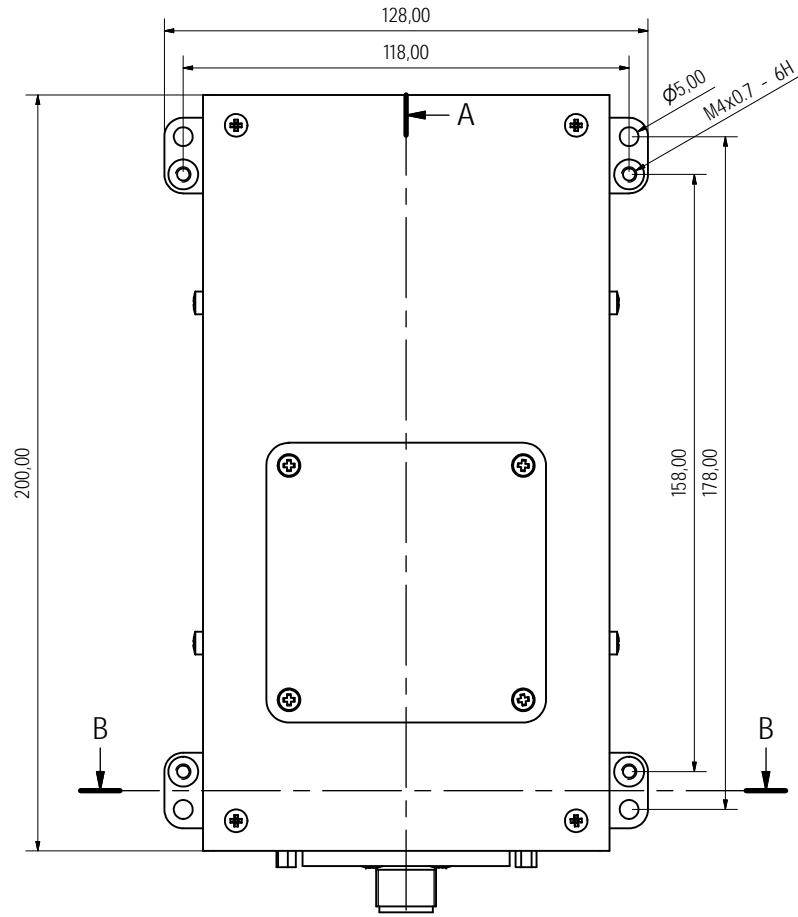

B-B (1:1)

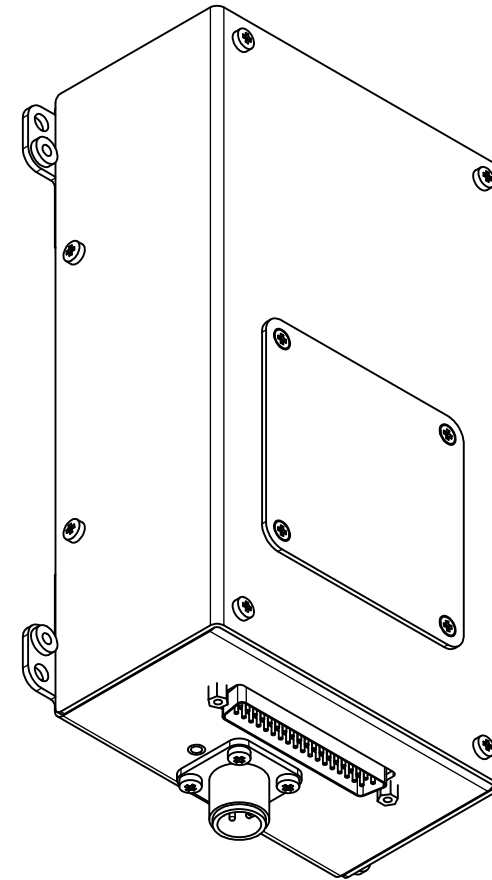
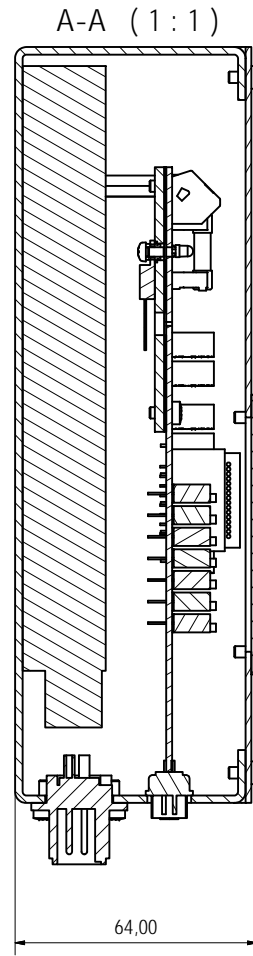
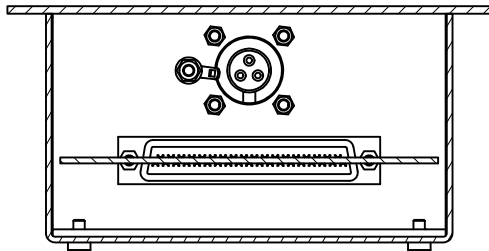

Für diese Unterlagen behalten wir uns alle Rechte vor (DIN 34)

Ges. f. Rationalisierung und Rechentechnik mbH Ob der Eck 4 78148 Gutenbach		Datum	Name		
		12.09.2007	ps	ST103 Baugruppe	
				dnr16949	
				2	
				A2	
Status	Änderungen	Datum	Name		

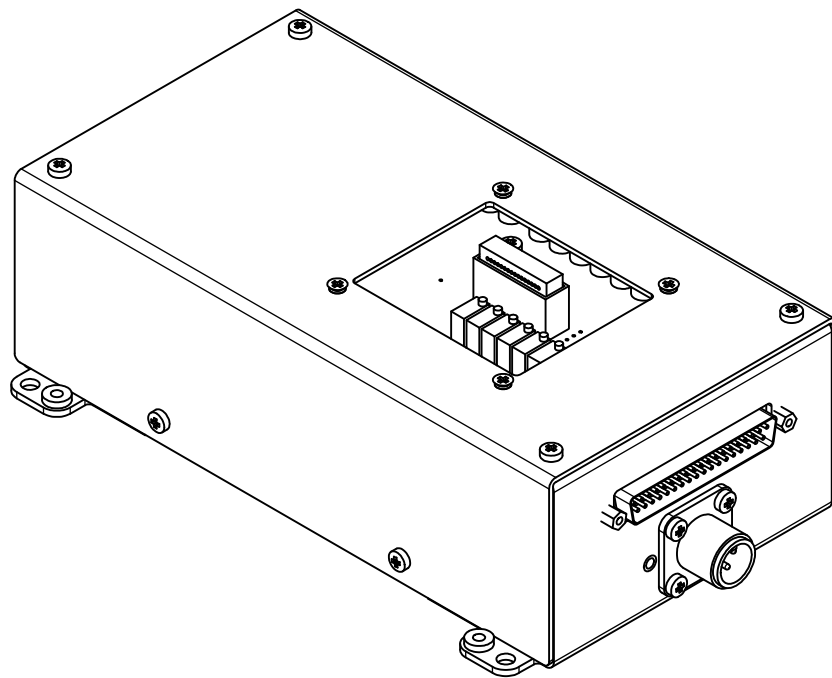

Für diese Unterlagen behalten  
wir uns alle Rechte vor (DIN 34)

Ges. f. Rationalisierung und Rechentechnik mbH Ob der Eck 4 78148 Gutenbach							
				Datum	Name		
				Sonstschreib	12.09.2007	ps	ST103 Baugruppe
				Kontrolliere			
				Norm			
Status	Änderungen	Datum	Name			dnr16949	3 A2